

ParkWest Professional Plaza

*Quality
Office Space
in Hilliard
at an
Affordable
Price*



ParkWest Professional Plaza is situated in the city of Hilliard-in the Heart of Ohio. Hilliard is one of the fastest growing cities in Ohio. In fact it is one of the fastest growing communities in America! This dynamic, rapidly developing city makes Hilliard an ideal location for you business

Hilliard's convenient location makes this city a favorite for businesses as well as homeowners. Hilliard prides itself on the quality of its city services, schools, excellent parks and superior recreational activities. An excellent highway infrastructure is also in place; Hilliard's easy entry to the outerbelt system is most certainly a bonus.

Surrounded by a beautiful park like setting, ParkWest is a prestigious, easy-to-reach office complex consisting of suites ranging in size from 1,152 S.F. to 5,760 S.F. ParkWest consists of 10 building, designed with over 50 office suites. The office buildings sport an appealing architectural design and are attractively grouped together in a meticulously maintained landscape. ParkWest office suites feature open, flexible floorplans and are all on ground level with convenient, ample parking within a few steps of each suite's entrance.



Consider making your next business move to...*ParkWest Professional Plaza.*

COMMERCIAL
InSite
REAL ESTATE
(614) 799-5563
(614) 761-1561 fax
www.krebergroup.com

All information furnished regarding property for sale or lease is from sources we deem reliable. There is no warranty or representation made as to the accuracy of this information. This submission may be modified or withdrawn at any time by the property owner.

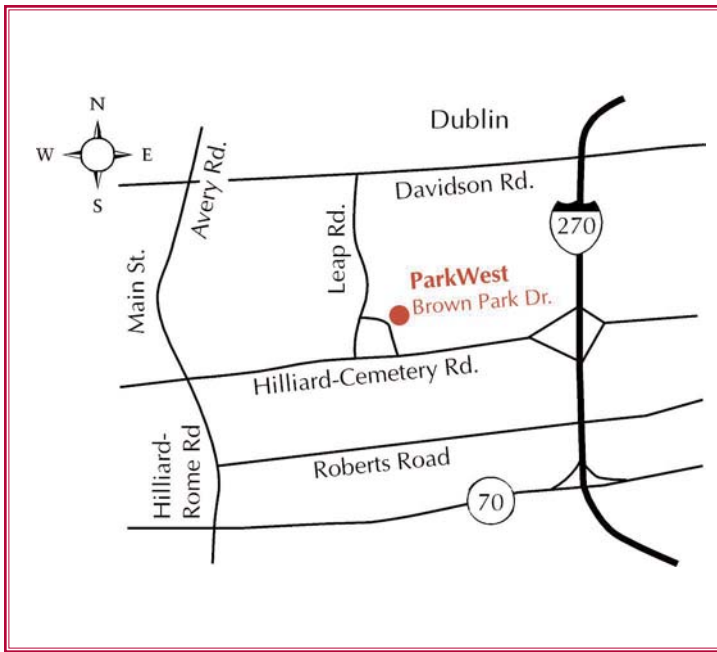

LOCATION:

This exceptional office space location offers easy access to I-270, which connects with I-71, the Cleveland to Cincinnati interstate and I-70, the east/west interstate, which provides access to downtown Columbus. In addition, ParkWest is surrounded by a variety of businesses including banks, restaurants, shopping, hotels and children’s day care, which are just minutes away.

Floor Plan #1

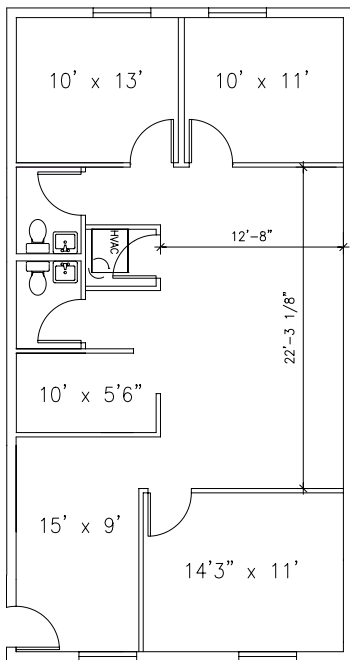

Floor Plan #2

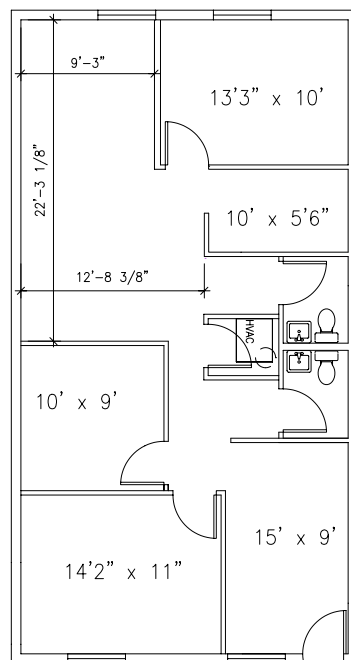

THE AMENITIES:

- Desirable office space in the premier suburb of Hilliard
- Appealing architectural design with high quality construction standards
- Minutes from I-270 and I-70
- Beautiful park-like campus setting
- Professional management for superior
- Class A service
- Individual heating and cooling systems
- Ample and well-illuminated parking
- Open floor plans allow for flexibility
- Immediate occupancy
- Affordable lease rates
- High speed internet access available



LEASING INFORMATION
 For leasing information, contact
 (614) 799-5563
 (614) 761-1561 fax
 www.krebergroup.com



PROFESSIONAL MANAGEMENT
 Kreber Group, Ltd., a professional management company founded in 1972, proudly manages ParkWest Professional Plaza.
 (614) 761-3300
 (614) 761-1561
 www.krebergroup.com